

Certification Report

SN220 Series - Secure Element with Crypto Library SN220_SE B0.1 C13

Sponsor and developer: ***NXP Semiconductors Germany GmbH***
Troplowitzstrasse 20
22529 Hamburg
Germany

Evaluation facility: ***Riscure B.V.***
Delftechpark 49
2628 XJ Delft
The Netherlands

Report number: **NSCIB-CC-0258298-CR**

Report version: **1**

Project number: **0258298**

Author(s): **Hans-Gerd Albertsen**

Date: **18 August 2021**

Number of pages: **14**

Number of appendices: **0**

Reproduction of this report is authorised only if the report is reproduced in its entirety.

CONTENTS

Foreword	3
Recognition of the Certificate	4
International recognition	4
European recognition	4
1 Executive Summary	5
2 Certification Results	6
2.1 Identification of Target of Evaluation	6
2.2 Security Policy	6
2.3 Assumptions and Clarification of Scope	7
2.3.1 Assumptions	7
2.3.2 Clarification of scope	8
2.4 Architectural Information	8
2.5 Documentation	9
2.6 IT Product Testing	10
2.6.1 Testing approach and depth	10
2.6.2 Independent penetration testing	11
2.6.3 Test configuration	11
2.6.4 Test results	11
2.7 Reused Evaluation Results	11
2.8 Evaluated Configuration	12
2.9 Evaluation Results	12
2.10 Comments/Recommendations	12
3 Security Target	13
4 Definitions	13
5 Bibliography	14

Foreword

The Netherlands Scheme for Certification in the Area of IT Security (NSCIB) provides a third-party evaluation and certification service for determining the trustworthiness of Information Technology (IT) security products. Under this NSCIB, TÜV Rheinland Nederland B.V. has the task of issuing certificates for IT security products, as well as for protection profiles and sites.

Part of the procedure is the technical examination (evaluation) of the product, protection profile or site according to the Common Criteria assessment guidelines published by the NSCIB. Evaluations are performed by an IT Security Evaluation Facility (ITSEF) under the oversight of the NSCIB Certification Body, which is operated by TÜV Rheinland Nederland B.V. in cooperation with the Ministry of the Interior and Kingdom Relations.

An ITSEF in the Netherlands is a commercial facility that has been licensed by TÜV Rheinland Nederland B.V. to perform Common Criteria evaluations; a significant requirement for such a licence is accreditation to the requirements of ISO Standard 17025 “General requirements for the accreditation of calibration and testing laboratories”.

By awarding a Common Criteria certificate, TÜV Rheinland Nederland B.V. asserts that the product or site complies with the security requirements specified in the associated (site) security target, or that the protection profile (PP) complies with the requirements for PP evaluation specified in the Common Criteria for Information Security Evaluation. A (site) security target is a requirements specification document that defines the scope of the evaluation activities.

The consumer should review the (site) security target or protection profile, in addition to this certification report, to gain an understanding of any assumptions made during the evaluation, the IT product's intended environment, its security requirements, and the level of confidence (i.e., the evaluation assurance level) that the product or site satisfies the security requirements stated in the (site) security target.

Reproduction of this report is authorised only if the report is reproduced in its entirety.

Recognition of the Certificate

The presence of the Common Criteria Recognition Arrangement (CCRA) and the SOG-IS logos on the certificate indicates that this certificate is issued in accordance with the provisions of the CCRA and the SOG-IS Mutual Recognition Agreement (SOG-IS MRA) and will be recognised by the participating nations.

International recognition

The CCRA was signed by the Netherlands in May 2000 and provides mutual recognition of certificates based on the Common Criteria (CC). Since September 2014 the CCRA has been updated to provide mutual recognition of certificates based on cPPs (exact use) or STs with evaluation assurance components up to and including EAL2+ALC_FLR.

For details of the current list of signatory nations and approved certification schemes, see <http://www.commoncriteriaportal.org>.

European recognition

The SOG-IS MRA Version 3, effective since April 2010, provides mutual recognition in Europe of Common Criteria and ITSEC certificates at a basic evaluation level for all products. A higher recognition level for evaluation levels beyond EAL4 (respectively E3-basic) is provided for products related to specific technical domains. This agreement was signed initially by Finland, France, Germany, The Netherlands, Norway, Spain, Sweden and the United Kingdom. Italy joined the SOG-IS MRA in December 2010.

For details of the current list of signatory nations, approved certification schemes and the list of technical domains for which the higher recognition applies, see <https://www.sogis.eu>.

1 Executive Summary

This Certification Report states the outcome of the Common Criteria security evaluation of the SN220 Series - Secure Element with Crypto Library SN220_SE B0.1 C13. The developer of the SN220 Series - Secure Element with Crypto Library SN220_SE B0.1 C13 is NXP Semiconductors Germany GmbH located in Hamburg, Germany and they also act as the sponsor of the evaluation and certification. A Certification Report is intended to assist prospective consumers when judging the suitability of the IT security properties of the product for their particular requirements.

The TOE is a Single Chip Secure Element and NFC controller Series combines on a single die an Embedded Secure Element, an NFC Controller, and the Power Management Unit. The three subsystems are called "SN220_SE", "SN220_PMU", and "SN220_NFC". The NFC Controller and the PMU are not part of the TOE.

The TOE is the Secure Element SN220_SE and is available in one configuration SN220_SE B0.1 C13. The TOE will be provided with IC Dedicated Software comprising Crypto Library, Services Software, and IC Dedicated Support Software.

The TOE is a Security Integrated Circuit Platform for various operating systems and applications with high security requirements.

This TOE is critically dependent on the operational environment to provide countermeasures against specific attacks as described in sections 2.1, and 4.1 of SN220_SE Information on Guidance and Operation and sections 6.1.5, 6.2.8 of SN220x Crypto Library Information on Guidance and Operations (both as referenced in the [ST]). As such it is vital that meticulous adherence to the user guidance of both the software and the hardware part of the TOE is maintained.

The TOE has been evaluated by Riscure B.V. located in Delft, The Netherlands. The evaluation was completed on 16 August 2021 with the approval of the ETR. The certification procedure has been conducted in accordance with the provisions of the Netherlands Scheme for Certification in the Area of IT Security [NSCIB].

The scope of the evaluation is defined by the security target [ST], which identifies assumptions made during the evaluation, the intended environment for the SN220 Series - Secure Element with Crypto Library SN220_SE B0.1 C13, the security requirements, and the level of confidence (evaluation assurance level) at which the product is intended to satisfy the security requirements. Consumers of the SN220 Series - Secure Element with Crypto Library SN220_SE B0.1 C13 are advised to verify that their own environment is consistent with the security target, and to give due consideration to the comments, observations and recommendations in this certification report.

The results documented in the evaluation technical report [ETR]¹ for this product provide sufficient evidence that the TOE meets the EAL6 augmented (EAL6+) assurance requirements for the evaluated security functionality. This assurance level is augmented ALC_FLR.1 (Flaw Remediation) and ASE_TSS.2 (TOE Summary Specification with architectural design summary).

The evaluation was conducted using the Common Methodology for Information Technology Security Evaluation, Version 3.1 Revision 5 [CEM] for conformance to the Common Criteria for Information Technology Security Evaluation, Version 3.1 Revision 5 [CC] (Parts I, II and III).

TÜV Rheinland Nederland B.V., as the NSCIB Certification Body, declares that the evaluation meets all the conditions for international recognition of Common Criteria Certificates and that the product will be listed on the NSCIB Certified Products list. Note that the certification results apply only to the specific version of the product as evaluated.

¹ The Evaluation Technical Report contains information proprietary to the developer and/or the evaluator, and is not available for public review.

2 Certification Results

2.1 Identification of Target of Evaluation

The Target of Evaluation (TOE) for this evaluation is the SN220 Series - Secure Element with Crypto Library SN220_SE B0.1 C13 from NXP Semiconductors Germany GmbH located in Hamburg, Germany.

The TOE is comprised of the following main components:

Delivery item type	Identifier	Version
Hardware	SN220_SE (base layer and fixed metal masks)	B0.1
Software (IC Dedicated Support Software)	Factory OS (ROM)	9.0.4
	Boot OS (ROM)	9.0.3
	Flash Driver Software (ROM)	9.0.2

Table 1 Components common for all SN220_SE B0.1.

Delivery item type	Identifier	Version
Configuration Data	Factory Page	21043
	System Page Common	21031
	BootOS Patch	9.0.3 PL1 v1
Security Software	Services Software (ROM)	9.17.4
	Crypto Library (ROM & Flash)	2.2.0

Table 2 Components of SN220_SE B0.1 specific for C13

To ensure secure usage a set of guidance documents is provided, together with the SN220 Series - Secure Element with Crypto Library SN220_SE B0.1 C13. For details, see section 2.5 “Documentation” of this report.

For a detailed and precise description of the TOE lifecycle, see the [ST], Chapter 1.3.3.

2.2 Security Policy

The security functionality of SN220_SE is designed to act as an integral part of a security system composed of SN220_SE and Security IC Embedded Software to strengthen it as a whole. Several security mechanisms of SN220_SE are completely implemented in and controlled by SN220_SE. Other security mechanisms must be treated by Security IC Embedded Software. All security functionality is targeted for use in a potential insecure environment, in which SN220_SE maintains:

- correct operation of the security functionality
- integrity and confidentiality of data and code stored to its memories and processed in the device
- controlled access to memories and hardware components supporting separation of different applications.

This is ensured by the construction of SN220_SE and its security functionality.

SN220_SE basically provides:

- hardware to perform computations on multiprecision integers, which are suitable for public-key cryptography
- hardware to calculate the Data Encryption Standard with up to three keys
- hardware to calculate the Advanced Encryption Standard (AES) with different key lengths

- hardware to support Cipher Block Chaining (CBC), Cipher Feedback (CFB), Output Feedback (OFB) and Counter (CTR) modes of operation for symmetric-key cryptographic block ciphers
- hardware to support Galois/Counter Mode (GCM) of operation and Galois Message Authentication Code (GMAC) for symmetric-key cryptographic block ciphers
- hardware to calculate Cyclic Redundancy Checks (CRC)
- hardware to serve with True Random Numbers
- hardware and service software to control access to memories and hardware components.

In addition, SN200_SE embeds sensors, which ensure proper operating conditions of the device. Integrity protection of data and code involves error correction and error detection codes, light sensing and other security functionality. Encryption and masking mechanisms are implemented to preserve confidentiality of data and code. The IC hardware is shielded against physical attacks.

The Crypto Library consists of several binary packages that are pre-loaded to the Flash memory of the TOE for usage by the Security IC Embedded Software. The Crypto Library provides:

- AES
- Triple-DES (3DES)
- Multi-precision arithmetic operations including exact division, secure modular addition, secure modular subtraction, secure modular multiplication, secure modular inversion, secure arithmetic comparison and secure exact addition
- RSA
- RSA key generation
- RSA public key computation
- ECDSA (ECC over GF(p)) signature generation and verification
- ECDSA (ECC over GF(p)) key generation
- ECDH (ECC Diffie-Hellmann) key exchange
- MontDH (Diffie Hellman key exchange on Montgomery Curves over GF(p)) key generation
- MontDH (Diffie Hellman key exchange on Montgomery Curves over GF(p)) key exchange
- EdDSA (Edwards-curve Digital Signature Algorithm) signature generation and verification
- EdDSA (Edwards-curve Digital Signature Algorithm) key generation
- ECDA related functions
- Full point addition (ECC over GF(p))
- Standard security level SHA-1, SHA-224, SHA-256, SHA-384, SHA-512, SHA-3/224, SHA-3/256, SHA-3/384, SHA-3/512, SHAKE128/256 algorithms
- High security level SHA-1, SHA-224, SHA-256, SHA-384, SHA-512, SHA-3/224, SHA-3/256, SHA-3/384, SHA-3/512, SHAKE128/256 algorithms
- HMAC algorithms
- eUICC authentication functions (MILENAGE, TUAK and CAVE)
- Hash-based key derivation function according to ANSI X9.63.

In addition, the Crypto Library implements a software (pseudo) random number generator which is initialized (seeded) by the hardware random number generator of the TOE. The Crypto Library also provides a secure copy routine, a secure memory compare routine, cyclic redundancy check (CRC) routines, and includes internal security measures for residual information protection.

2.3 Assumptions and Clarification of Scope

2.3.1 Assumptions

The assumptions defined in the Security Target are not covered by the TOE itself. These aspects lead to specific Security Objectives to be fulfilled by the TOE-Environment. For detailed information on the security objectives that must be fulfilled by the TOE environment, see section 4.2 and 4.3 of the [ST].

2.3.2 Clarification of scope

The evaluation did not reveal any threats to the TOE that are not countered by the evaluated security functions of the product.

2.4 Architectural Information

IC Hardware

The SN220x Single Chip Secure Element and NFC controller Series combines on a single die an Embedded Secure Element, an NFC Controller, and the Power Management Unit. The three subsystems are called “SN220_SE”, “SN220_PMU”, and “SN220_NFC”. The NFC Controller and the PMU are not part of the TOE.

The TOE is the Secure Element SN220_SE and is available in one configuration SN220_SE B0.1 C13. The TOE will be provided with IC Dedicated Software comprising Crypto Library, Services Software, and IC Dedicated Support Software.

A block diagram is given in Figure 1 below.

The hardware part of the SN220_SE incorporates a high frequency clocked ARM SC300 processor, a Public-Key Cryptography (PKC) coprocessor and a Direct Memory Access (DMA) controller, which are all connected over a Memory Management Unit (MMU) to a bus system. This bus system gives access to memories, hardware peripherals and communication interfaces.

The ARM SC300 processor is a security enhanced variant of the ARM Cortex M3. It includes the SC300 core and the Nested Vector Interrupt Controller (NVIC). The core implements the ARMv7-M architecture, which supports a subset of the Thumb instruction set. The PKC coprocessor provides large integer arithmetic operations, which can be used by Security IC Embedded Software for asymmetric-key cryptography. Hardware peripherals include coprocessors for symmetric-key cryptography and for calculation of error-detecting codes, and also a random number generator. The DMA controller manages data transfers over communication interfaces like ISO/IEC 7816 compliant interface, Serial Peripheral Interface (SPI), I2C interface and the Secure Mailbox Interface. On-chip memories are Flash memory, ROM and RAMs. The Flash memory can be used to store data and code of Security IC Embedded Software. It is designed for reliable non-volatile storage.

SN220_SE is offered with the NXP Trust Provisioning Service, which involves secure reception, generation, treatment and insertion of customer data and code at NXP.

The documentation of SN220_SE includes a product data sheet, several product data sheet addenda, a user guidance and operation manual, and service documentation. This documentation describes secure configuration and secure use of SN220_SE as well as the services provided with it.

Also, the IC Dedicated Support Software is considered part of the IC Hardware, as it is stored to the ROM of the TOE. It consists of the Factory OS, the Boot OS and the Flash Driver Software.

Security Software

The IC Dedicated Software provides Security Software that can be used by the Security IC Embedded Software. The Security Software is composed of Services Software and Crypto Library.

The Services Software consists of Flash Services Software, Services Framework Software and the part of the Services HAL (Hardware Abstraction Layer) that is not stored to ROM. The Flash Services Software manages technical demands of the Flash memory and serves the Security IC Embedded Software with an interface for Flash erase and/or programming. The Services Framework Software represents a collection of different abstractions and utility functions that provide a runtime environment to the individual Services. The Services HAL provides an interface for the Services Software to the hardware that controls the Flash memory.

The Services Software is considered part of the Service Code and is stored in the Flash memory of the TOE.

The Crypto Library is described in section 2.2 above.

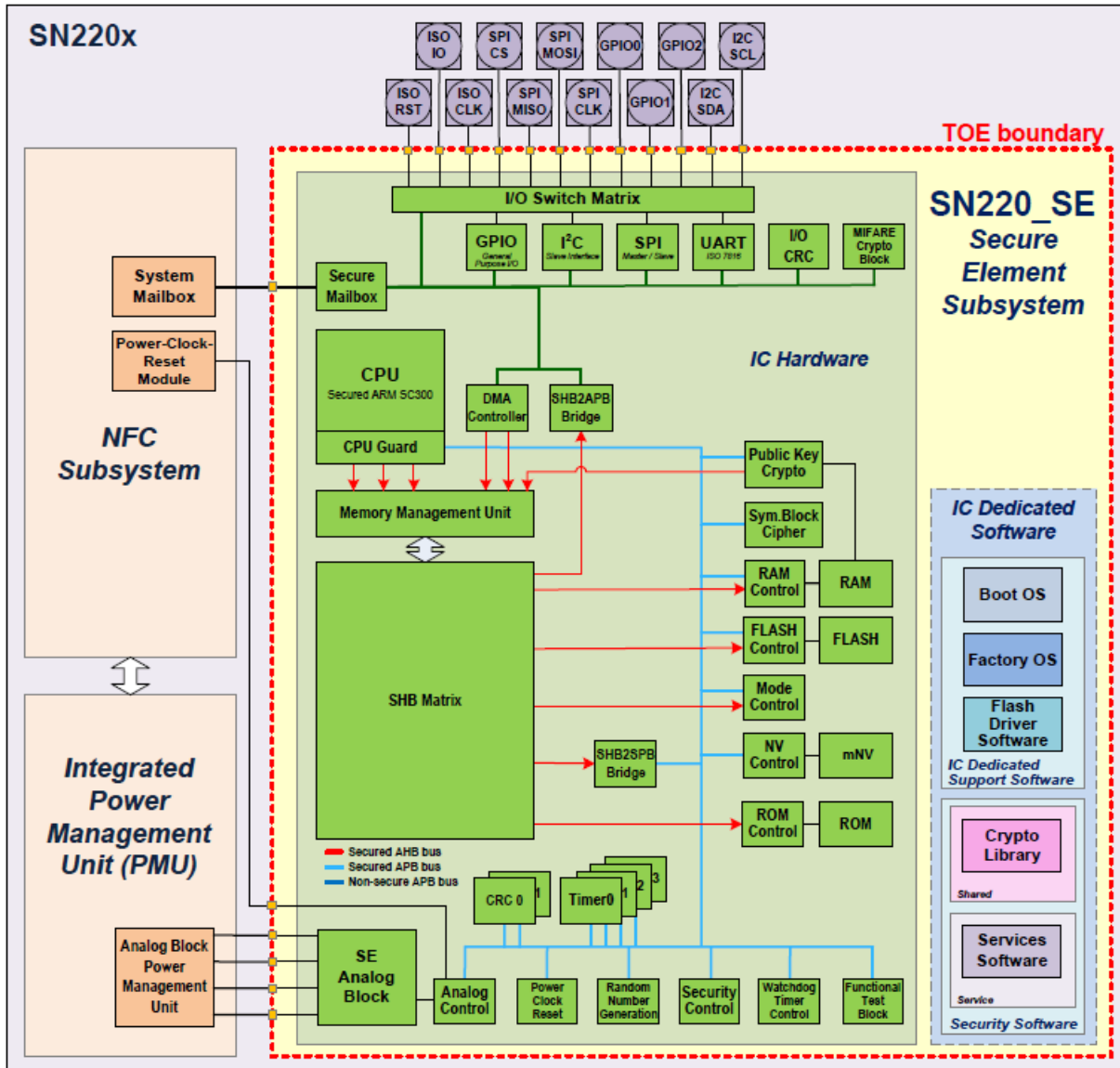

Figure 1 Logical architecture of the TOE

2.5 Documentation

The following documentation is provided with the product by the developer to the customer:

Identifier	Version
SN220x_SE High-performance secure elements subsystem, Product Data Sheet	v1.0
SN220x_SE – SFR Tables for Coburg Core	v0.1
SN220x Wafer and Delivery Specification, Product Data Sheet addendum	v1.0
P73 Family SC300 User Manual, Product Data Sheet addendum	v1.0
P73 Family DMA Controller PL080 User Manual, Product Data Sheet addendum	v1.0
P73 Family Chip Health Mode, Application note	v1.0
P73 Family Code Signature Watchdog, Application note	v1.1

ARM®v7-M Architecture Reference Manual	DDI 0403E.b (ID120114)
--	---------------------------

Table 3 Manuals common for all SN220_SE B0.1

Identifier	Version
SN220_SE Information on Guidance and Operation	v1.0
SN220 Services User Manual - API and Operational Guidance	v1.0
SN220 Services Addendum – Additional API and Operational Guidance	v1.0
SN220x Crypto Library Information on Guidance and Operation	v1.1
SN220x Crypto Library: User Manual: RNG	v1.0
SN220x Crypto Library: User Manual: Utils	v1.0
SN220x Crypto Library: User Manual: SymCfg	v1.0
SN220x Crypto Library: User Manual: RSA	v1.0
SN220x Crypto Library: User Manual: RSA Key Generation	v1.0
SN220x Crypto Library: User Manual: ECC over GF(p)	v1.0
SN220x Crypto Library: User Manual: ECDA	v1.0
SN220x Crypto Library: User Manual: SHA	v1.0
SN220x Crypto Library: User Manual: SecSHA	v1.0
SN220x Crypto Library: User Manual: SHA3	v1.0
SN220x Crypto Library: User Manual: SecSHA3	v1.0
SN220x Crypto Library: User Manual: HMAC	v1.0
SN220x Crypto Library: User Manual: HASH	v1.0
SN220x Crypto Library: User Manual: TwdEdMontGfp	v1.0
SN220x Crypto Library: User Manual: eUICC	v1.0
SN220x Crypto Library: User Manual – Kdf Library	v1.0
SN220x Crypto Library: User Manual – Utils Math	v1.0

Table 4 Manuals of SN220_SE B0.1 specific for C13

2.6 IT Product Testing

Testing (depth, coverage, functional tests, independent testing): The evaluators examined the developer's testing activities documentation and verified that the developer has met their testing responsibilities.

2.6.1 Testing approach and depth

The developer performed extensive testing on functional specification, subsystem and modules (according to EAL6 requirements). The testing was largely automated using industry standard and proprietary test suites. Test scripts were extensively used to verify that the functions return the expected values.

The underlying hardware and crypto-library test results are extendable to composite evaluations, because the underlying platform is operated according to its guidance and the composite evaluation requirements are met.

For the testing performed by the evaluators, the developer provided samples and a test environment. The evaluators reproduced a selection of the developer tests, as well as a small number of test cases designed by the evaluator. For the evaluator defined tests the developer delivered samples (and support in writing scripts). However, Riscure's test environment was used for these ATE_IND tests.

2.6.2 Independent penetration testing

The evaluator independent penetration tests were conducted according to the following testing approach:

- During evaluation of the ADV, ATE and ALC classes the evaluators hypothesized possible vulnerabilities. This resulted in a shortlist of possible vulnerabilities to be further analysed in AVA using the design knowledge gained in particular from the source code analysis in IMP. This resulted in a shortlist of potential vulnerabilities to be tested.
- Next the evaluators analysed the TOE design and implementation for resistance against the JIL attacks. This resulted in further potential vulnerabilities to be tested.
- The evaluators made an analysis of the TOE in its intended environment to check whether the developer vulnerability analysis in ARC has assessed all information.
- The evaluators concluded that a number of areas could be potentially vulnerable for attackers possessing a high attack potential. Consequently, practical penetration testing was performed for absolute assurance.

The total test effort expended by the evaluators was 24 weeks. During that test campaign, 60% of the total time was spent on Perturbation attacks, 35% on side-channel testing, and 5% on logical tests.

2.6.3 Test configuration

Testing was performed on slightly different configurations of the TOE SN220_SE B0.1 C13. The differences between these configurations and the TOE have been analysed. They have no impact on the test results, hence the test results apply to the TOE.

2.6.4 Test results

The testing activities, including configurations, procedures, test cases, expected results and observed results are summarised in the [ETR], with references to the documents containing the full details.

The developer's tests and the independent functional tests produced the expected results, giving assurance that the TOE behaves as specified in its [ST] and functional specification.

No exploitable vulnerabilities were found with the independent penetration tests.

The algorithmic security level of cryptographic functionality has not been rated in this certification process, but the current consensus on the algorithmic security level in the open domain, i.e., from the current best cryptanalytic attacks published, has been taken into account.

Not all key sizes specified in the [ST] have sufficient cryptographic strength for satisfying the AVA_VAN.5 "high attack potential". The TOE supports a wider range of key sizes (see [ST]), including those with sufficient algorithmic security level to exceed 100 bits as required for high attack potential (AVA_VAN.5).

The strength of the implementation of the cryptographic functionality has been assessed in the evaluation, as part of the AVA_VAN activities. So, no exploitable vulnerabilities were found with the independent penetration tests.

For composite evaluations, please consult the [ETRFc] for details.

2.7 Reused Evaluation Results

There has been extensive reuse of the ALC aspects for the sites involved in the development and production of the TOE, by use of 26 site certificates and 26 Site Technical Audit Reuse report approaches.

No sites have been visited as part of this evaluation.

2.8 Evaluated Configuration

The TOE is defined uniquely by its name and version number SN220 Series - Secure Element with Crypto Library SN220_SE B0.1 C13. The user can identify the certified configuration by reading the TypeID bytes. The details are described in the guidance documentation.

2.9 Evaluation Results

The evaluation lab documented their evaluation results in the *[ETR]*, which references an ASE Intermediate Report and other evaluator documents, To support composite evaluations according to *[CCDB-2007-09-01]* a derived document *[ETRFc]* was provided and approved. This document provides details of the TOE evaluation that must be considered when this TOE is used as platform in a composite evaluation.

The verdict of each claimed assurance requirement is “**Pass**”.

Based on the above evaluation results the evaluation lab concluded the SN220 Series - Secure Element with Crypto Library SN220_SE B0.1 C13, to be **CC Part 2 extended, CC Part 3 conformant**, and to meet the requirements of **EAL 6 augmented with ALC_FLR.1 and ASE_TSS.2**. This implies that the product satisfies the security requirements specified in Security Target *[ST]*.

The Security Target claims 'strict' conformance to the Protection Profile *[PP_0084]*.

2.10 Comments/Recommendations

The user guidance as outlined in section 2.5 “Documentation” contains necessary information about the usage of the TOE.

This TOE is critically dependent on the operational environment to provide countermeasures against specific attacks as described in sections 2.1, and 4.1 of SN220_SE Information on Guidance and Operation and sections 6.1.5, 6.2.8 of SN220x Crypto Library Information on Guidance and Operations (both as referenced in the *[ST]*). Therefore, it is vital to maintain meticulous adherence to the user guidance of both the software and the hardware part of the TOE.

In addition, all aspects of assumptions, threats and policies as outlined in the Security Target not covered by the TOE itself must be fulfilled by the operational environment of the TOE.

The customer or user of the product shall consider the results of the certification within his system risk management process. For the evolution of attack methods and techniques to be covered, the customer should define the period of time until a re-assessment for the TOE is required and thus requested from the sponsor of the certificate.

The strength of the cryptographic algorithms and protocols was not rated in the course of this evaluation. This specifically applies to the following proprietary or non-standard algorithms, protocols and implementations: KoreanSeed (out of scope), OSCCA SM2, OSCCA SM3 and OSCCA SM4 (out of scope), and FeliCa (out of scope).

Not all key sizes specified in the *[ST]* have sufficient cryptographic strength to satisfy the AVA_VAN.5 “high attack potential”. To be protected against attackers with a “high attack potential”, appropriate cryptographic algorithms with sufficiently large cryptographic key sizes shall be used (references can be found in national and international documents and standards).

3 Security Target

The SN220 Series - Secure Element with Crypto Library Security Target, Version 1.0, 12 July 2021 [ST] is included here by reference.

Please note that, to satisfy the need for publication, a public version [ST-lite] has been created and verified according to [ST-SAN].

4 Definitions

This list of acronyms and definitions contains elements that are not already defined by the CC or CEM:

AES	Advanced Encryption Standard
CBC	Cipher Block Chaining (a block cipher mode of operation)
CBC-MAC	Cipher Block Chaining Message Authentication Code
DES	Data Encryption Standard
DFA	Differential Fault Analysis
ECB	Electronic Code Book (a block-cipher mode of operation)
ECC	Elliptic Curve Cryptography
ECDH	Elliptic Curve Diffie-Hellman algorithm
ECDSA	Elliptic Curve Digital Signature Algorithm
EMA	Electromagnetic Analysis
IC	Integrated Circuit
IT	Information Technology
ITSEF	IT Security Evaluation Facility
JIL	Joint Interpretation Library
MAC	Message Authentication Code
MITM	Man-in-the-Middle
NSCIB	Netherlands Scheme for Certification in the area of IT Security
PP	Protection Profile
RNG	Random Number Generator
RSA	Rivest-Shamir-Adleman Algorithm
SHA	Secure Hash Algorithm
SPA/DPA	Simple/Differential Power Analysis
TOE	Target of Evaluation
TRNG	True Random Number Generator

5 Bibliography

This section lists all referenced documentation used as source material in the compilation of this report.

[CC]	Common Criteria for Information Technology Security Evaluation, Parts I, II and III, Version 3.1 Revision 5, April 2017
[CEM]	Common Methodology for Information Technology Security Evaluation, Version 3.1 Revision 5, April 2017
[ETR]	Evaluation Technical Report for SN220 Series – Secure Element with Crypto Library B0.1 C13, Doc ID: 20190523-D3, Version 1.3, 13 August 2013
[ETRFc]	ETR for composite evaluation SN220 Series – Secure Element with Crypto Library B0.1 C13, Doc ID: 20190523-D4, Version 1.3, 13 August 2013
[JIL-AM]	Attack Methods for Smartcards and Similar Devices, Version 2.4, January 2020 (sensitive with controlled distribution)
[NSCIB]	Netherlands Scheme for Certification in the Area of IT Security, Version 2.5, 28 March 2019
[PP_0084]	Security IC Platform Protection Profile with Augmentation Packages, registered under the reference BSI-CC-PP-0084-2014, Version 1.0, 13 January 2014
[ST]	SN220 Series - Secure Element with Crypto Library Security Target, Version 1.0, 12 July 2021
[ST-lite]	SN220 Series – Secure Element with Crypto Library Security Target, Version 1.0, 12 July 2021
[ST-SAN]	ST sanitising for publication, CC Supporting Document CCDB-2006-04-004, April 2006

(This is the end of this report.)